

REWINDING CABLE REELS FOR PASSIVE GROUNDING TYPE 601 KR/EW

Zones 1, 2, 21, 22

Full catalogue available on our website: www.inpratex.com

ATEX EARTHING SYSTEMS

ZONES 1, 2 (gas) & 21, 22 (dust)

The 601KR/EW rewinding cable reel is available in an impact-resistant aluminum casing and can hold a grounding cable of up to 12 m. For use without ground monitoring system in Zones 1, 2, 21 and 22. It is supplied with 70PK type clamp.

This reel is designed for wall mounting, but can also be swivel-mounted using a mounting bracket. A coupling plug can be used to easily connect the passive 70PK clamp with the coupling bushing of the grounding cable.

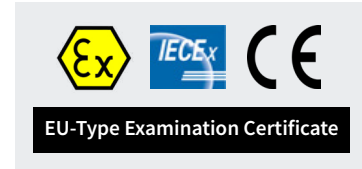

ITEM REFERENCES

Designation:	Cable length:	Connection cable length:	Weight:	Item No.:
601KR/EW - 70PK	12 m	2,5 m	Approx. 6 kg	6D0701

70 PK CLAMP TECHNICAL SPECIFICATIONS

Marking:	II 1G IIB T6 Ga, II 2G IIC T6 Gb, II 1D T80°C Da
Certificate:	EU-Type Examination Certificate
Clamp material:	Stainless steel
Operating temperature:	-20°C to +70°C
Ground cable: (color: orange)	Oil and gasoline resistant control lead, 3 x 1.5 mm ² Temperature range -40...+90°C Connected 4-pin plug IP67
Dimensions:	See figure
Weight:	Approx. 0.29 kg
Clamping width:	35 mm
Clamping force:	100 N ±20%
Earth leakage resistance:	< 1 Ohm

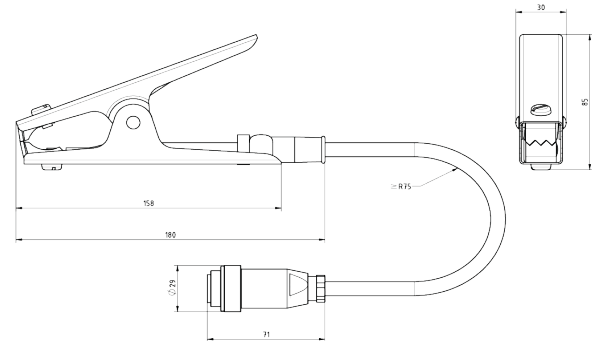

601KR/EW CABLE REWINDER TECHNICAL SPECIFICATIONS

Marking:	II 2G Ex ia IIC T6 Gb II 2D Ex ia IIIC T135°C Db
Certificate:	EU-Type Examination Certificate
Enclosure:	Aluminium with rolls and stopper
Ingress protection:	IP42 according to EN 60529
Operating temperature:	-40°C to +70°C
Attachment:	Wall assembly via assembly bracket
Ground cable: (12 M)	Oil and gasoline resistant control lead, 3 x 1.5 mm ² Temperature range -40...+90°C Connected 4-pin socket IP67
Connecting lead:	2.5 m, connecting cable 3 x 1,5 mm ²
Dimensions:	See figure
Weight:	Approx. 5.7 kg with 12 m ground cable
Inductance:	Approx. 0.07 mH
Capacitance:	Approx. 1.6 nF

