

# EX-PROOF HORN SPEAKER DSP-15EEXMN(T)

Zones 1, 2, 21, 22

Full catalogue available on our website: [www.inpratex.com](http://www.inpratex.com)

## ACOUSTIC SIGNALLING DEVICES

ZONES 1, 2 (gas) & 21, 22 (dust)



This versatile 25W Ex plastic horn speaker is light in weight and features a spacious connection chamber of protection type 'e'. It has dual M20 entries in the back lid for easy cable mounting and supports loop in loop out as standard.

This model has extensive certification qualifying it for use in nearly all corners of the world.

The model can be ordered with different transformers for more choices of power tapings and power ratings.



EU-Type Examination Certificate

### ITEM REFERENCES

Designation:	Item No.:
DSP-15EExmN(T)	3D0401

### TECHNICAL SPECIFICATIONS

Marking:	II 2G Ex db eb mb IIB+H <sub>2</sub> / IIC T4 Gb II 2D Ex tb IIIC T105°C Db	
Certificate:	EU-Type Examination Certificate	
Operating temperature:	-50°C to +60°C	
Housing:	Anti-static PA / Black	
Mounting:	Bracket	
Termination:	e-chamber, push terminals	
Weight w/transformer:	2,2 kg	
Ingress protection:	IP66/67	
Rated voltage:	100V	
Rated / max. power:	25W / 30W	
	IIB+H <sub>2</sub>	IIC
Sound pressure level 1W/1m:	106 dB	102 dB
Sound pressure level rated power:	118 dB	114 dB
Effective freq. range:	380-8000 Hz	450-7000 Hz
Cable entries:	2xM20x1.5 plastic plugs	

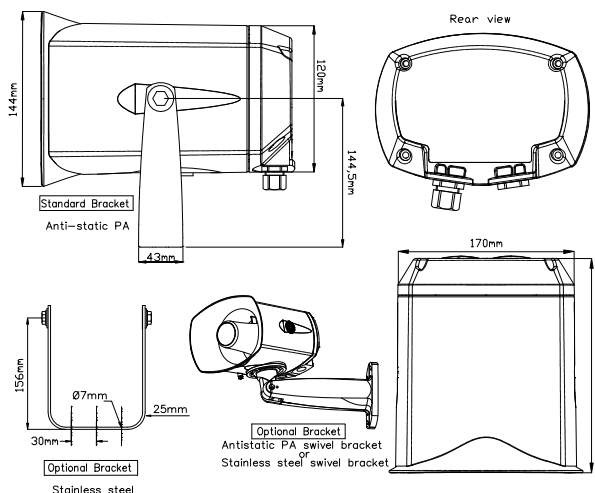

### CIRCUIT DIAGRAM

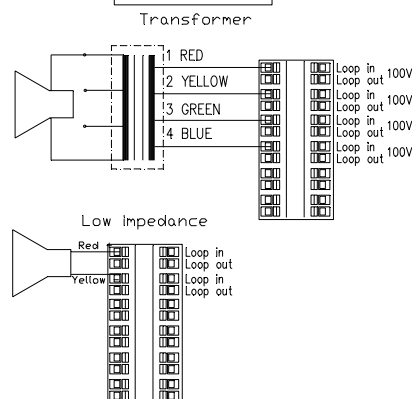

### PRIMARY NOMINAL TAPPINGS

1 : 2	25,0 W
2 : 3	15,0 W
3 : 4	6,5 W
1 : 3	5,0 W
2 : 4	2,5 W
1 : 4	1,5 W